

## Chapter 4

### A Theory of Systems

The first three chapters of this study examined the work of many scholars as applied to the problem of the rise and decline of Great Powers. I found that students of international relations have not directly addressed the crucial question of what constitutes a Great Power, and the writings concerning rise and decline have not seriously investigated the nature of technological change as applied to production. In both cases, then, critical questions have gone unanswered.

When these issues are raised, the answers given are, to a certain extent, ad hoc. According to Webster's dictionary, "ad hoc" means "for this (special purpose)". The definition of a Great Power, and the causes of productive technological change, are ad hoc because they are not linked to a wider, general purpose set of theories which are constructed in order to address these issues. By constructing a set of theories in the next several chapters, I will attempt to anchor the answers to these important questions onto a firm theoretical foundation.

In order to address these questions, therefore, it is necessary to start by investigating how to explain complex systems in general. Once a wider view of a complex system has been constructed, then it will be possible to become more concrete. It will become possible to explore systems that are pertinent to the questions of rise and fall of Great Powers, in particular, political, economic, and production systems. These theories, in turn, can then be used to suggest hypotheses, which are amenable to empirical validation or refutation. By the end of this process, the definition of Great Powers and

the causes for their rise and decline should be understood as part of a theoretical framework, not as a set of ad hoc answers.

### ***REDUCTION AND EMERGENCE***

What is the proper way to model a phenomenon as complex as the rise and decline of Great Powers? There are two basic techniques for understanding complex phenomena, analysis and systemic explanation (Laszlo 1996).

Analysis has been the mainstay of scientific and social scientific scholarship (Waltz 1979, 39). Researchers investigate a subject of study, and break down the large unit, such as an economy, into smaller units, such as industries. Once the smaller unit is understood, the scholar can then *aggregate* the results obtained for the smaller units in order to understand the larger one. The most common example of such a methodology takes place in the realm of physics, in which a mechanical system can be understood by being divided into its parts, and by summing the results of the analysis of those parts in order to understand the whole.

The assumption in using analytical methodology is that a unit of analysis is decomposable. Once the unit has been separated into components, those components may likewise be disaggregated into yet smaller units, and so on. Any phenomenon can be disaggregated into its smaller parts, and those parts can likewise be decomposed. This process of decomposition can be carried on until the realm of subatomic physics is reached, in which decomposition is no longer possible (although physicists are constantly trying to explore smaller levels).

This movement from one subject matter to another can be characterized as movement from one *domain of inquiry* to another. A domain of inquiry can be defined as

a general class of phenomena that are usually studied together, and are often categorized in terms of academic disciplines, such as biology, chemistry, and physics.

Since the analytical process can proceed across several levels of inquiry, any domain of inquiry can be conceived to be located at a certain level in a *hierarchy* of domains (O'Neill et al. 1986). For example, biologists commonly describe their field in terms of multiple levels of inquiry. Starting with the study of large organic chemicals, a biology textbook might move to the study of cells and their components (microbiology), then to the study of organs and the organism (physiology), and finally to a discussion of ecology. Ecology can also be studied at various levels: from the study of populations of the same species (population ecology) to the study of communities of plants and animals (community ecology) to the ecosystem as a whole, which includes inanimate forces (see for example, [Campbell et al. 1999, Chapter 1] as well as [Mayr 1997, 18]).

All of these biological levels occur within the same academic discipline, although usually practicing biologists specialize in one level. Once we descend downward below biology, however, the domain of inquiry moves to the entirely different discipline of chemistry. Below this level, the discipline may change again, to the physics of atoms and finally to the quantum mechanics within the atom.

The following diagram is an example of a complete hierarchy:

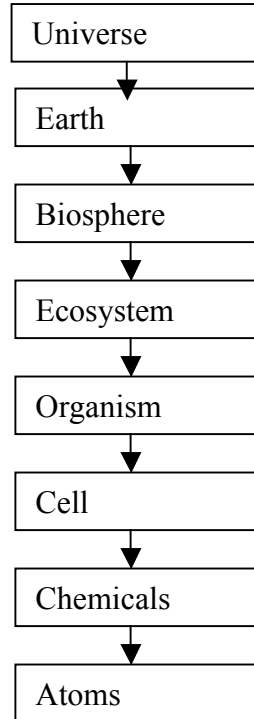

Fig. 9. Example of complete hierarchy.

Each level can be decomposed into components at the level below, and each level generally contains several levels. We can imagine many different manifestations of this hierarchy.

For instance, we might consider humans as a kind of organism, and we might further disaggregate human society thus:

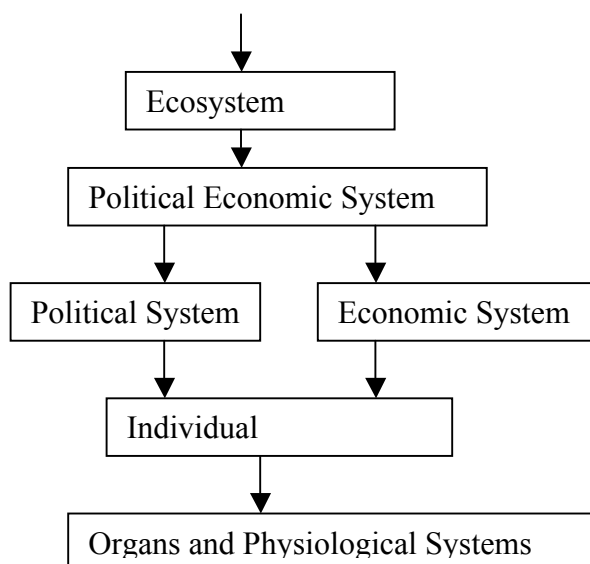

Fig. 10. Example of human society as hierarchy.

The arrows pointing into and out of this diagram indicate that there are other levels in the hierarchy, but they are not all being shown here.

There may be different hierarchies of domains of inquiry depending on the phenomena that are of interest. Figure 10 will serve as a guide to the next chapters, which will expand on the simple model of conceiving of human society as a system of political economy composed of political and economic subsystems.

The act of describing one domain of inquiry in terms of the domain below it is called *reduction*. The field of the philosophy of science is filled with debates on the appropriateness and applicability of this process (see for example, [Mayr 1997], [Nagel 1961], or [Phillips 1976]). At one extreme in the debate is the famous claim made by the mathematician LaPlace, that if he knew the position of every piece of matter in the universe at a particular point in time, he could predict all following events (Nagel 1961,

281). Chaos theory, or more formally nonlinear dynamic theory, has had the result of throwing this claim into serious doubt, even for mechanical processes (see, for example, Holte 1993).

At the other end of the debate, some have argued that the unit of analysis, far from being understood as an aggregation of parts, must be understood as containing properties which are only apparent at the level of the unit or whole, not at the level of the components. Instead of using the methodology of analysis, these authors are concerned with *systemic explanation*, or holistic thinking. One famous example is water; one could not predict the properties of water just by knowing the properties of its constituent parts, oxygen and hydrogen. New properties are said to *emerge* (Phillips 1976, 14 and Mayr 1997, 19) from the interaction of oxygen and hydrogen. Thus, instead of going *down* the hierarchy of domains, one can go *up* the hierarchy in order to understand more completely the phenomena in question. In figures 9 and 10, the arrows would flow up, instead of down.

The extreme position, sometimes ascribed to Hegel or Hegelians, is that one cannot understand an object unless one understands the whole of which it is a part, and to understand the whole one must understand the whole of which *it* is a part, until one arrives at the position that one must understand the entire universe in order to understand anything. Bertrand Russell was thus afforded the opportunity to quip, “If all knowledge were knowledge of the universe as a whole, there would be no knowledge” (Phillips 1976, 11).

Both “extreme” positions would seem to be impractical. The extreme reductionist approach would always fail, because even with the fastest, largest computers imaginable,

it would still be impossible even to fully predict the action of one ocean wave, much less the entire universe. The extreme holistic approach would paralyze research, because even if it were true that one must understand everything in order to understand anything absolutely, no person could achieve such wisdom in one lifetime. The practical solution is to assume that, at each level in a hierarchy of inquiry, new properties do emerge, and further that much of the functioning of a whole can be explained by analyzing the components. In short, both reduction and emergence are useful, whether or not they have some ultimate, untestable validity.

The eminent biologist Mayr calls this synthesis in biology “organicism”, which “is best characterized by the dual belief in the importance of considering the organism as a whole, and at the same time the firm conviction that this wholeness is not to be considered something mysteriously closed to analysis...” (Mayr 1997, 20).

## **SYSTEMS**

This thing which is the object of inquiry, whether it is an economy, atom, organism, or universe, shall be called a *system* in this study, and the component parts shall be called units, elements, or components, interchangeably. It shall be assumed that all phenomena, with the possible exception of subatomic particles, are systems composed of units, and that all systems, with the possible exception of the universe, are themselves components of other systems.

There have been many proposals for a theory of systems (see, for example, [Buckley 1968], and [Jervis 1997, 6]). The concept of cybernetics (Wiener 1954) in particular has been used by scholars in many disciplines as a theory of systems. The

development of cybernetics was motivated by the functioning of machinery. The focus was on machinery which processes information, such as computers, or production machinery and weapons which use sophisticated control systems. The classic example of a cybernetic system, however, is a heating system with a thermostat. The basic idea in a cybernetic system is that there is a target value at which the system should stabilize. If the system is not at this target value, it should move toward it. Any deviations from this target are automatically removed or minimized by the actions of the system. A thermostat, for example, turns on the heating system when the ambient temperature is less than the target temperature, and turns off the heating system when the ambient temperature is greater than the target temperature. A cybernetic system is therefore often called a negative feedback process, because it tends to be stable, it tries to minimize change, and it is capable of monitoring its variables.

This approach caught the imagination of many thinkers and scientists in the 1960's. For instance, Ludwig van Bertalanffy developed a "General Systems Theory" which was closely patterned on the cybernetic model (Bertalanffy 1968). He used his theory to describe many processes, mainly in the cell and in the organism. General Systems Theory could claim to model such domains, since there is a control element, or aspect, of a cell and an organism that allows for cybernetic-like negative feedback processes to occur.

However, the vast majority of systems do not have a control element which senses the environment and adjusts the other elements accordingly. In particular, economic and ecological systems do not generally have any centralized control, and even political systems do not have the fine-tuned control elements that are useful in machinery. A



theory of systems does not require the inclusion of a master controller which keeps the system from flying apart; ecosystems and economies are a testament to this fact.

In addition, systems theory based on cybernetics cannot explain change which is not consciously designed; unplanned change is considered to be a breakdown of a cybernetic system. Most systems, such as economies and ecosystems, are not only capable of unplanned change, but actually thrive on it. Most innovation is unplanned. Thus, cybernetic theories have many of the problems of neoclassical economic theories, which concentrate on stability and equilibrium.

The international relations theorist Kenneth Waltz has drawn on cybernetic and other systems theorists (Waltz 1979, 40) to construct a theory of systems which will be used as a basis for the theory of systems proposed in this study. Although Waltz also stresses the stability of systems, by extending his framework and further incorporating many of the scholarly sources of Waltz's work, it will be possible to construct a theory of systems which is useful for explaining change and stability.

The first task in constructing a theory of systems is to distinguish between, first, the elements and their interactions, and second, the emergent properties of the system (Waltz 1979, 78-80). The *unit level* of a system can be described as the collection of elements and their interactions. The *system level* of a system can refer to two sets of properties that emerge from the interaction of those components: 1) the domain of the system; and 2) the structure of the system.

The *domain* of a system serves to describe the object as a whole, and helps to place the system within a hierarchy of domains; thus we can refer to an ecosystem, an economy, or a polity, as the domain of a system. This is an abstract definition; when we

discuss an actual occurrence of, say, an economy or nation, we are referring to an *instantiation* of a domain; thus we refer to the “French economy” or “the United States”, which are instantiations of economies and polities. Part of the definition of the domain includes the boundary between an instantiation of a system and its environment, as between one polity and the rest of the international political system.

Sometimes it is desirable to divide a domain. For instance, the social sciences contain disciplines such as economics and political science, which study different phenomena within society. We can call these *subdomains*. Such a classification was shown in figure 10; in later chapters the definitions of the subdomains of politics and economics will be explored.

Finally, each abstract definition may be further subdivided into various *types* or kinds of the particular system; for instance, there are democratic political systems and dictatorial political systems. These types are differentiated according to the second aspect of a system, the structure; a different structure yields a different type of a particular class of systems.

## **STRUCTURE**

The structure is the way in which the elements are arranged within a system; a structure is the way in which a system is organized. There have been myriad attempts to define the term ‘structure’ (see Phillips 1976, chapter 6). Perhaps Plato had the most extreme view of the importance of structure, or form. He postulated that reality was a reflection of various forms, which were thought to be prior to material reality. Plato’s

concept of forms was asserted to be more important than the concept of substance, which interested the Greek philosophers of the time (thus, the substances of fire, water, air and earth were said to be basic). Aristotle, Plato's student, then took the logical high road and claimed that form and substance were both important (see introductions of Aristotle's *Physics* [Aristotle 1996] and *Metaphysics* [Aristotle 1998]). This study will take a similar position; the elements or units of a system may be seen to be its substance, or material, and the structure may be said to be its form.

For Waltz, both the elements and structure are important, but he wishes to concentrate his attention on the structure, which will be the focus of this study as well. By focusing on the structure of production in chapters 6 through 8, it will be possible to fruitfully explore the question of productive technological change.

In Waltz's view, the organization of the elements in a system can be further divided into two general aspects: first, an ordering principle; and second, the way the parts are arranged in accordance with the ordering principle. For instance, to take one of Aristotle's favorite examples, a statue is ordered in space; the various parts of the bronze statue are placed in various positions relative to other pieces of bronze, and the relative positions of the various pieces are responsible for replicating the desired image. If the positions of the pieces are changed, the new statue is said to be different than the old, even if the pieces are the same. One could take the same quantity of bronze and produce a statue of a person or a fish; the difference in structure would yield the difference between the two.

The anthropologist Claude Levi used the example of a symphony to explicate two other orderings. Each instrument in a symphony plays notes at specific points in time,

while at each moment in time within a symphony certain instruments are playing and certain instruments are not playing. The symphony is ordered both in time and as a set of specific interacting units (Phillips 1976, 88). Thus, there may be more than one ordering principle at work within a structure.

Waltz's concepts of ordering principle and organization seem to have been influenced by a paper he references, by Angyal. For Angyal, "the members of a system...do not become constituents of the system by means of their immanent qualities, but by means of their distribution or arrangement within the system. The object does not participate in the system by an inherent quality but by its *position in the system*" (Angyal 1939, 28, emphasis in original). This position of the members may be spatial or temporal. Further, since objects must be separable in order to study them, Angyal argues that "multiplicity of objects is only possible in some kind of dimensional medium. The clearest examples of dimensional media are space and time...*Systems are the kinds of distributions of the members in a dimensional medium*" (Angyal 1939, 29, emphasis in original). Waltz and this study use the term "ordering principle" instead of the term dimensional medium. Angyal also emphasizes that a system is not the same as the interactions of the elements: "In a system the members do not hang together among themselves but they hang together as a whole" (Angyal 1939, 30).

While Waltz bases his ideas on the writings of scholars who use orderings of time and space as illustrative examples, Waltz himself is concerned with political systems. He therefore uses the social ordering principle of hierarchy as his sole "dimension medium". In an organization or polity, there exists a fairly strict line of authority, emanating from a top officer, such as a CEO or President, flowing downward through

various middle levels of the bureaucracy, and finally enforcement imposed on the citizens or employees who are required to follow the laws that are enacted further up the hierarchy. In the international political system, on the other hand, there exists no sequence of command. Truly independent states are said to be in an anarchic relation with each other; that is, there is no relation of authority and command. Waltz's ordering principle yields two possible values for a political system: hierarchic or anarchic.

Realist scholars such as Waltz have always been concerned with the lack of moral restraint on the part of states which an anarchic condition seems to encourage. Modern realists have not been particularly interested in the position of states in space or time, however. The idealist scholar in international relations has also treated states as a set of entities which did not exist in space or time, but which exist in a "society" that orders the states and therefore constrains their behavior. Hedley Bull combined the two concepts in his important work, *The Anarchic Society* (Bull 1977).

An earlier group of international relations scholars, interested in the geographical or "geopolitical" aspects of international power, were concerned with the structure of the international system in terms of an ordering in space. Mackinder conceived of the globe as being affected by the existence of a "Heartland", a "Rimland", and lands in between, all having a particular spatial relation. Mahan emphasized the importance of the seas, since these provided a way to encircle enemies and connect imperial possessions and trade routes (Luard 1992, 231-6). Thus various ordering principles have been used by international relations scholars.

This study will be concerned with ordering in time within a system, as well as hierarchic ordering. Rise and decline occurs through time, and it will be shown that economies and systems of political economy are ordered, in part, through time.

## ***THE ARRANGEMENT OF PARTS***

Waltz divides his second aspect of structure, the arrangement of parts, into two other concepts, functional differentiation and the distribution of capabilities.

The understanding of function has been very important in anthropology, from which much of the discussion of structure arose (see Phillips 1976, chapter 6). Domestic political systems are also characterized by functional differentiation, as in the American division among the legislative, executive, and judicial branches, as well as the Federal distribution between the national and the state governments.

One branch of social science that has been virtually impervious to any discussion of functional differentiation is economics. Whether the goal is to explain the setting of prices or the existence of competition, oligopoly, or monopoly, all firms are conceived of as being essentially the same except in terms of size. In other words, in neoclassical economic analysis, the units are identical except for size. Instead, my conceptions of economic and production systems will emphasize the functional differentiation among elements, as I will explain in chapters 6 through 8.

Waltz uses the basic idea of the similarity of elements except for size in order to characterize the international political system. Like an industrial sector, all states are essentially similar; instead of differing in size, according to Waltz, states differ in terms

of relative capabilities. Therefore, one of the aspects of the arrangement of parts, functional differentiation, is not used by Waltz; only the distribution of capabilities becomes important for Waltz's conception of an international political system.

This system of similarity except for capabilities, it will be argued, is more appropriate for the international political system than for the economic system, for the units in the former carry out similar tasks. It is useful to divide the economy into functional units, each of which carries out different tasks in the operation of a modern industrial economy.

Waltz uses the term "distribution of capabilities" to describe the structure of political systems, but the term "distribution of values" is more useful as a general phrase which can apply to many kinds of systems. In a statue, the mass of the bronze is distributed in space, while in an international political system the capabilities of states are distributed in an environment of anarchy. The critical condition for being able to describe a "distribution of values" is that there be a common measure among all the elements or units of the system. If there is a common measure, the observer can ascertain how the values are distributed or positioned or allocated.

As was pointed out in Chapter 1, the general definition of this common measure of capabilities in international relations is not well-specified; capability is claimed to be an aggregation of many different measures, such as leadership, economic output, and population. The definition of a Great Power can be consistent with the definition of the common measure, since a Great Power will be distinguished by having more of a common measure than other nations. In the next chapter I will attempt to describe a theoretically rigorous definition of the term "Great Power".

Since Waltz does not need to use the concept of functional differentiation in order to describe the international political system, he does not explore the conceptual tension that exists between “functional differentiation” and “distribution of values”. When two units have different functions, it may be difficult to detect a common measure; two things which have different functions by definition have something which is not similar. For example, what is common between a legislative branch, which passes legislation, a judicial branch, which uses the legislation to adjudicate disputes, and the executive branch, which is supposed to enforce the legislation? American historians often write about the difference in the relative power among the branches; for example, the late nineteenth century was alleged to have been a time of Congressional dominance over the President. But this sense of relative capabilities is rarely given a common measure.

Many other systems besides the international political one are characterized by functional differentiation. For example, an organism is composed of many functional elements, as is an ecosystem. The components are distributed, but they are distributed according to the ordering principles of time and space; the common measure would therefore be in terms of time and space. Similarly, the economic system, it will be argued, is functionally distributed and ordered in time and space, as well as according to the capability to output economic value.

In ecosystem theory, the problem of reconciling functions with a common measure has been at least partly resolved by viewing the ecosystem as a system for converting energy in a sequence of stages (Campbell et al, 1134-38). The sequence is generally specified to start at the sun. In the next stage, primary producers such as plants capture solar energy. The primary consumers such as plant-eaters (herbivores) then



convert the stored energy of the plants into their own forms of energy. Finally, secondary consumers in the form of carnivores receive solar energy indirectly by eating herbivores. A recycling stage of decomposers such as bacteria and fungi feed on all of the other stages.

Each stage (or trophic level, as it is called) serves a function in the ecosystem, and each stage can be measured for its intake of energy. For instance, a common finding is that only 10% of the energy of one stage is transferred to the next; this is why there are very few carnivores in a forest or grasslands. On the other hand, the carnivores serve a very important function; they help keep the herbivores in check, which allows the foundation of the ecosystem, the plants, to survive.

In much the same way, we can look at the economy as a set of stages of output of economic value, each of which serves a particular function. The chapters concerning economic systems will elaborate on this idea.

## A GENERAL MODEL OF SYSTEMS

I have now specified most of the main elements of a theory of systems. A conceptual diagram of a system might therefore consist of the following:

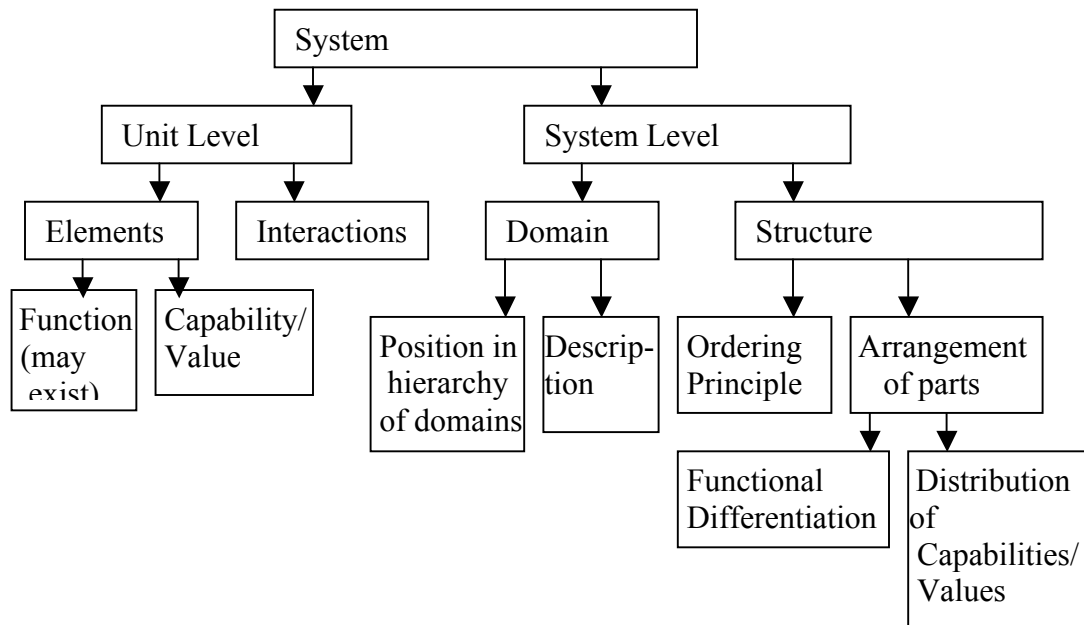

Fig. 11. Model of a system.

The theory of systems as embodied in figure 11 consists of a series of levels. On the first level, the system can be examined at either a unit level or a system level.

On the unit level, we are concerned with knowing which set of elements is in the system. The function served by an element, if there is one, is the property of each element. The capability or value that the element possesses is also a property of each element. We need not specify more than this for each element, because an element is itself a system, the description of which will give a fuller account of the element.

There is a set of interactions among the elements. As will be explained later, the most important interactions among elements are involved with feedback processes. In addition, there are always a certain set of elements which have particular kinds of

interactions with outside systems; these elements and their interactions may be termed *interfaces*. For example, the foreign policy apparatus of a state is the primary political interface of a polity.

The system level is divided between the domain and the structure. The domain consists of two parts: a description of the system as a whole; and a link to the larger system of which the current system under study is a part.

The structure itself is divided into two parts, the ordering principle and the arrangement of the units. The arrangement of the units is then divided into a functional differentiation and a distribution of capabilities/values.

At the *element* level of the system, the function and value of the element must be specified so that these functions and values can be used to ascertain the functional differentiation and distribution of values that constitute the *structure* of a system. For example, the various functions of the organs of the body are specified as the functions of a particular set of elements. Using this information, the functional differentiation of the structure can be described.

The aggregation of the capabilities/values of all of the elements of a system constitutes the capability/value of the system as a whole. This value becomes the value of the system when it is considered as an element in the domain at a higher level. Thus, the aggregate output of all firms in an industry becomes the value of the industry when the industry becomes an element in the domain of the entire economy. It may not be possible to aggregate values, however.

The function of the element on one level is the same as the domain of the system at a lower level. Thus the function of a legislature within the state is to make laws, while the domain of the system called Congress or Parliament is as a law-making institution.

Thus, by specifying the various aspects of the system at all the levels of a hierarchy of domains, one can also specify how the systems fit together. Much of the specification of a system depends on how the functions and capabilities/values are defined.

### ***SEQUENCES AND THE DISTRIBUTION OF CAUSAL CAPABILITY***

The system has now been specified as a collection of ordered elements. In order to understand dynamic processes such as the rise and decline of Great Powers, however, it is necessary to understand some of the basic processes that characterize systems. The first step in this understanding involves exploring the role of sequences in a system, partly because production involves sequences, as will be seen in chapter 6.

Sequences play a central role in the processes of most systems. A sequence is the manifestation of an ordering in time within a system, such as the notes in a melody or the stages of an assembly line. Martin Johnson writes that “physical science is interested in the changing or the flux of world, not in any static picture, and is in fact a study of a sequence of events whose basic pattern is a time-order” (Johnson 1951, 413).

Waltz cautions that the structure of a system must be carefully separated from the interactions of the elements, or else the system level and unit level may become confused, and the effects of the structure become unclear. A sequence, as on an assembly line or ecosystem, usually involves some sort of interaction among elements in the movement of

substance from one stage to another. This interaction properly belongs at the unit level. But the *necessity* of the interaction is determined by the way in which the stages are organized; that is, the structure is separate from the interactions.

For example, in a large factory, there may be a machine shop which produces parts and an assembly line which puts together the parts; this was the design of Ford's first factories. The way in which the parts are moved from the machine shop to the assembly line has changed in the 20<sup>th</sup> century, from relatively nonmechanized handling equipment to sophisticated cranes and monorails. But the need to move the parts from one stage to another has remained constant, because the process of production requires that parts be made before they are put together. As Waltz argues, the structure illuminates why, even while the attributes of the units change, certain processes of a system remain the same. Sequences help to explain this constancy and continuity of processes.

Sequences often imply the existence of a differentiation in the ability to cause change within a system. That is, there may be a *distribution of causal capability* among units. Let us say that the following sequence exists:

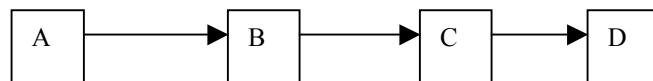

Fig. 12. Example of sequence of production.

Let us further say that this is a sequence of production in which A produces B, B produces C, and C produces D. If A changes for the better, A units will be able to produce better B units, which will mean that B units will be able to produce better C units, and C units will output better D units. Therefore, a change in A has led to an

improvement in *four* sets of elements, not just one. The change in one has reverberated, or been transmitted, throughout the system. However, if D changes for the better, this change will only effect D. A, B, and C will remain as they were before. Similarly, if B changes, C and D will change, and if C changes, C and D will change. So a change in A is worth 4 units, B is 3 units, C two units, and D only one unit. Because of the position of the units in the sequence, a change will have a different effect, depending on the changed unit's position. As will be shown in more detail in the following chapters, this kind of production sequence characterizes the economic system and the domestic political system.

Differentiation of causal capability is particularly important if we have, not a one-dimensional sequence, but a two- or three-dimensional one, such as the following:

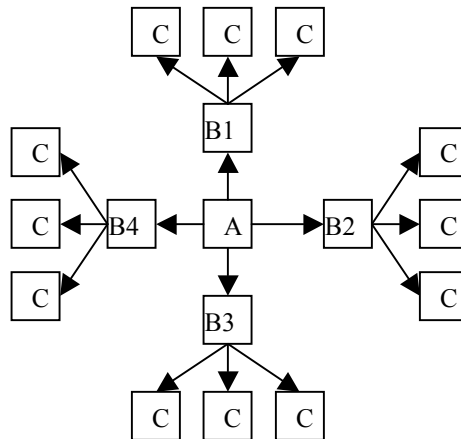

Fig. 13. Two-dimensional sequence.

In this system, a change in A will lead to a change in all Bs and then to a change in all Cs, whereas a change in a single B, say B2, will only lead to a change in B2 and its connected Cs. This sort of amplification of change is characteristic of economic systems and can be seen in the operation of ecosystems as well. For instance, when the dominant

plant-type became flowering plants (angiosperms), this change effected herbivores, and through herbivores, carnivores as well.

Is the distribution of the capability to change elements within the system a part of the specification of the structure? This causal capability depends on the unit's position within the system, not on the attributes of the unit itself. For instance, it will be argued that the machine tool industry has an importance in the economy which is much greater than can be ascertained by the monetary value of its output. This is not because machine tools are magical or more complex than other goods; it is because of their position in the structure of the economy.

This distribution of causal capability cannot even be specified in an absolute way, as can the capability in the distribution of capabilities. For instance, in figure 13, the unit A can be described absolutely according to a measure, and relatively as compared to other units, using the same measure, such as dollars of output. But the capability to cause change to other units can only be ascertained if the *position* of unit A is known; if analyzed as an isolated unit, in fact, unit A has *no* causal capability. Causal capability is *only* a relative capability, knowable from the structure of the system.

The distribution of this causal ability would seem to be a part of the structure. Waltz emphasizes that structures help to explain the lack of change in a system, but structures may help to explain change as well. The existence of a differentiation in causal capability leads to nonlinear processes within a system.

There has been much interest in many of the physical sciences in the nonlinear effects of particular causes. Much of this work has taken place under the label of chaos theory, which is a popularization of more descriptive terms such as nonlinear dynamic

processes. Maruyama has drawn attention to mutual causal systems, in which “the elements within a system influence each other either simultaneously or alternately,” leading to a situation in which “processes of mutual causal relationships ... amplify an insignificant or accidental initial kick, build up deviation and diverge from the initial condition” (Maruyama 1963, 164). Growth, whether of an organism, population, economy or a state, is a nonlinear process of change. It is therefore important to investigate the role of structure in nonlinear processes. When there is an uneven distribution of causal capability in the structure of a system, some element or elements have a greater capability to change the system than other units, so that a small change in one element may cause a disproportionate, or nonlinear, change in the system as a whole.

In neoclassical economic thinking, causal relationships are linear. No element in the system has greater causal capability than other elements. By contrast, I will show in chapters 6 through 8 how an analysis of production reveals differences in causal capability among elements of an economic system.

Waltz’s assumption of the importance of Great Powers has a certain nonlinear aspect. Out of a multitude of states, Waltz and others claim, there are only a few which are the focus of international attention. Great Powers have a certain “position” in the international system, but this position is more abstract than a position in a sequence or in space. Great Powers can be seen, however abstractly, as being in the position of Unit A in figure 13; change in the capabilities of Great Powers affects, not only the Great Powers, but all of the other states as well. The distribution of this capability is of a dualistic variety; either a state is or is not a Great Power. In a system which contains a



functionally differentiated sequence, the distribution of the capability to change elements is more varied than in the case of the international political system.

In a system that does not contain a sequence, then, it may be the case that one set of elements can be marked off as having a much greater effect on the system than other elements. To take an example from astronomy, when inquiring into the dynamics of a galaxy, only the stars are considered, as the planets and various other bodies are too small to make much of an effect.

In either a sequential or nonsequential system, this difference in capability to change elements may translate into an ability to change the structure itself. It will be argued in the next chapter that the Great Powers are those states that have the capability to reorder territorial allocation among states, the effect of which is to change the structure of the international political system.

For the purposes of simplifying the theory of systems, it will be assumed that functionally differentiated systems may include a varied distribution of causal capabilities among the units. In a nonfunctionally differentiated system, however, there may be only a dualistic distinction, between those elements that can cause extensive change in the system and those that can not. This dualism is based on the distribution of capabilities/values, where the difference in *values* is so great that a fundamental difference in causal capability occurs. For functionally differentiated systems, however, the distribution of causal capability is based on differences in *functions*.

The distribution of causal capability is based on either functional differentiation or distribution of values, but is different than either. Thus, the arrangement of parts of a structure can be decomposed into three elements: first, a differentiation of function;

second, a distribution of capabilities/values among units; and third, a distribution of causal capabilities among units.

## **GENERATION AND ALLOCATION**

In order for there to be a sequence in a system, it is necessary for there to be a functional differentiation of the elements within a system; it may be more or less difficult to establish a common measure of the units in order to describe a distribution of capabilities/values. I will call such systems *heterogeneous*.

If a system does not have a sequence, then it probably does not have a functional differentiation, and the specification of a common measure may therefore be easier. I will call systems with no functional differentiation *homogeneous*.

This dichotomy between functionally differentiated and homogenous systems suggests a fundamental difference between two types of systems. In a *generative* system, there is a functional differentiation which gives rise to a sequence of stages through time. This sequence involves the transformation of inputs which results in the creation of something new as the output.

We can find examples of generative sequences in many kinds of systems. A factory uses certain materials and intermediate goods as inputs. The factory then outputs intermediate goods of a different kind or finished goods. When organisms ingest materials and energy, they transform them into different kinds of materials and forms of energy within their bodies. When a carnivore in an ecosystem consumes another animal, such a process takes place at the end of a chain of energy and material transfers within

the ecosystem. When a law is enforced in a country, that enforcement is the end result of a sequence of processes involved in the creation and enforcement of laws. All of these processes involve transformation, generation, and creation.

An *allocative* system, on the other hand, is a system that allocates the substance that the generative system generates. The allocative system does not create anything new; it moves and distributes that which has already been created.

Most systems have an allocative aspect. The retail sector is used to distribute the final goods that are produced by factories, and the financial sector allocates the capital generated by the producing sectors of the economy. A biological example would be the circulatory system in animals, which distributes the sugars transformed by the digestive system throughout the body. Within the polity, the power to control the law-making process is allocated among all members of the population in a democracy, but such control is limited to only a few people in a dictatorship. In all of these processes, the allocative system does not create, but it fulfills the equally important function of distributing the output of the generative system.

An allocative subsystem has a distribution of values and causal capabilities but little or no functional differentiation. The specification of elements in an allocative system involves only values, and not functions.

A generative subsystem has a functional and causal differentiation, and may or may not have a distribution of values. The description of elements in a generative subsystem incurs the need to specify functions. The concept of a value in a generative system is primarily one of specifying the total output of the subsystem which is generated, not one of judging the relative contribution of each element to the output. For

instance, many industries contribute to the final output of the economy, and it may be difficult to attribute a precise quantity to each industry's role.

Since all parts of the generative system are often devoted to an end product, the intermediate stages can only be judged by the output of the whole, not by the elements' individual outputs. By contrast, as discussed in chapter 3, neoclassical theory posits that factors receive as income that which they contribute to the production process.

Some systems contain both generative and allocative systems within them; it may be said that such systems are *complete systems*, and are composed of two elements, allocative and generative *subsystems*. For example, an economy has both a production subsystem which generates goods and services, and an allocative subsystem which distributes this output. An organism has both a transformational subsystem which synthesizes chemicals, and a pulmonary-circulatory-waste subsystem which moves the synthesized products around and out of the body. As pointed out, an ecosystem is both a set of trophic levels, transforming different kinds of organisms into other kinds of organisms, and is a system which allocates energy and materials. A political system both creates laws and allocates control over the making of those laws. Generally, in order to understand the operation of complete systems, their generative and allocative subsystems must also be understood.

Sometimes a system can be seen as complete on one level, and then be viewed mainly as allocative or generative at the next level up in the hierarchy of domains. For example, a political system may be seen to be complete, but as part of a larger system of political economy, its allocative aspect might be emphasized.

Let us diagram a complete system as follows:

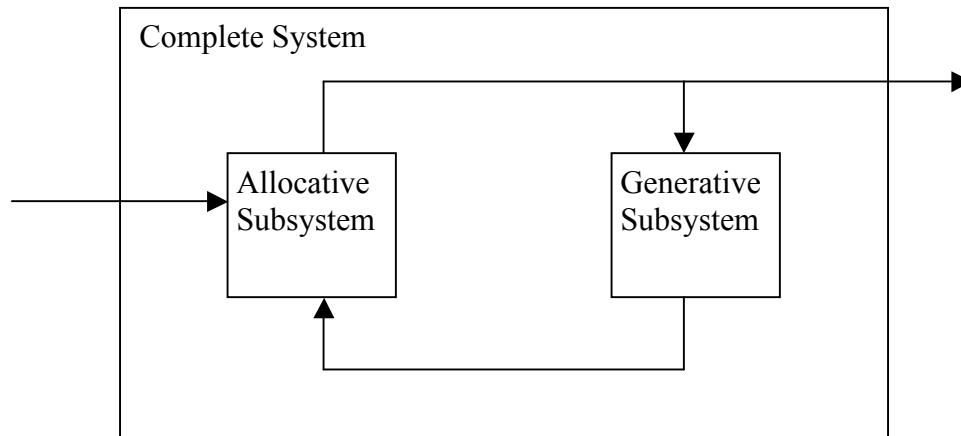

Fig. 14. A complete system.

The generative subsystem outputs a substance which the allocative subsystem directs back to the generative subsystem. The next chapters will explore the operation of this process for economic systems, political systems, and systems of political economy.

The diagram shows an arrow leading into the allocative subsystem and an arrow leading out from the allocative subsystem. All systems discussed in this study are *open* systems; that is, they receive inputs from other systems and send output to other systems. In this simplification of reality, only the allocative subsystem has control over flows into and out of a system.

The structure of a complete system is ordered in time, and is usually not a sequence but a *cycle*. Substance includes new elements in the system as well as the system's output. This substance is generated by the generator, then moved to the allocator, which transfers output back to the generator, and so on. The allocator, by distributing the output of the generator among all elements of the system, can therefore play an important role in changing the structure of the system.

The generator, on the other hand, is the source of the growth of a system. The generator cannot change the structure of the system of which it is a part, but the generator, by changing the aggregate value of the system of which it is a part, can change the structure of the system at the level *above* itself.

For instance, consider the following:

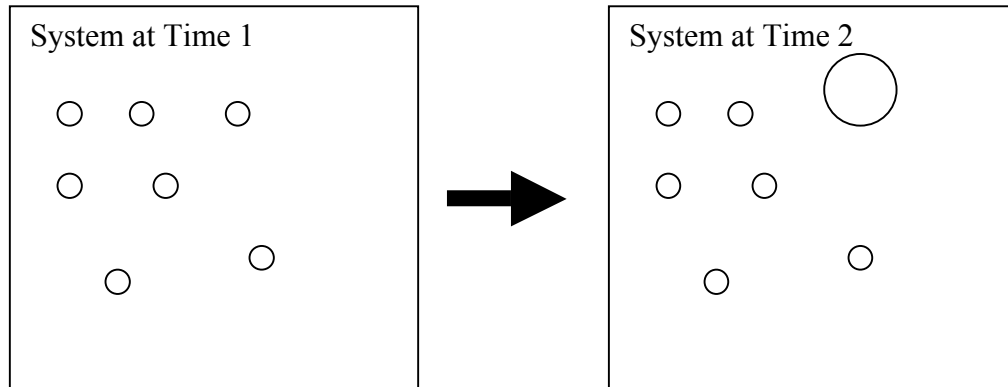

Fig. 15. Generating a change in structure.

The system at time 1 might represent an international political system in which all of the states have roughly similar capabilities. But say that one state has a capability generator which results in the state growing to such an extent that it then becomes much more powerful than the other states, as in the system shown at time 2. The internal structure of the state may not have changed, but the change in the total value of the state has changed the structure at the level above the state, the international political system.

The change in the total capability of the most powerful states, which leads to a change in the structure of the international political system, is the process of the rise and decline of Great Powers. The rise and decline of Great Powers can thus be seen within the context of the general theoretical framework presented in this chapter.

## **FEEDBACK PROCESSES**

A cycle may exist within a complete system made up of allocative and generative subsystems. A generative subsystem may also have cycles within it, such that parts of a sequence loop back to previous stages. This situation known as feedback. Feedback also characterizes allocative subsystems. These feedback processes explain much of the change and stability that occurs within systems.

There are two main types of feedback processes. In a negative feedback process, an increase or decrease in a value will lead, eventually, to a compensating decrease or increase in that value, respectively, and the system will be *stable*. In a positive feedback loop, an increase or decrease in a value will lead to a greater increase or decrease of the value in the following time period, and the system will be *dynamic*, or changing.

This study will focus on the operation of positive feedback loops, because this study is attempting to explain the causes of change in the relative power of Great Powers, not stability in the international political system (for a survey of positive feedback, see DeAngelis et al 1986 and Milsum 1968). The next chapters will therefore discuss the negative and positive feedback loops that characterize political systems, economic systems, and systems of political economy.

Allocative and generative subsystems have different feedback processes. An allocative system has nonfunctionally differentiated elements, and the structure is specified by the distribution of capabilities/values. When a unit has a greater value than its neighbor in an allocative subsystem, there is a tendency for the unit to control the neighbor; the allocative units are vying for control, and they allocate values, including other units, to themselves. An example of a mechanical allocative subsystem would be a

Newtonian gravitational system. Where the units are large enough – such as a star or planet – the sheer quantity of mass contained by the unit means that other units, of smaller size, will tend to be pulled within the gravitational field of the larger unit, and will be absorbed. Thus, when solar systems are forming, the proto-star pulls most of the mass of the solar system into itself. A positive feedback loop develops, wherein a certain amount of mass leads to the probability that an even larger amount of mass will be in the gravitational pull of the object.

The same phenomenon can be seen to occur in an international political system, which can be viewed as an allocative system. The larger the polity, relative to its neighbors, the better the probability that the polity will be able to absorb its neighbors. As Waltz (and others) have pointed out, however, this process is countered by the tendency for states to form a balance of power. A balance of power is an example of a negative feedback process forming in an allocative system.

Negative feedback processes form in allocative systems, in general, when a balance is achieved among the units so that no unit is large enough relative to the others to be able to absorb another unit. To return to the solar system example, the planets are at just the point in terms of mass, distance, and speed where they are large enough, far enough away from the sun, and revolving around the sun at the right speed so that they are not pulled into the sun's gravitational field.

Feedback processes in *allocative* systems therefore involve the aggregation of units into other units, in the case of positive feedback, and the countering of this effect, in the case of negative feedback.



Feedback processes in *generative* systems, on the other hand, involve the creation of substance at an exponential rate, in the case of positive feedback, and the necessity of the simultaneous, balanced growth of all units of a system, in the case of negative feedback.

For example, the foundation of the ecosystem (or community) is the ability of the organisms to reproduce, a positive feedback process. Organisms are capable of reproducing at an exponential rate. An exponential rate of growth is to be distinguished from a linear rate of growth. During a linear rate of growth, the original population will increase by a particular percentage, or will be multiplied by a particular number, in a certain period of time. For instance, in the realm of industry, if one can make 10 widgets in one hour, in 10 hours one can make 100 widgets.

In an exponential growth situation, on the other hand, the original population, numbering  $X$ , increases by an exponential, say  $N$ , denoted  $X^N$ . If we have 1 bacterium, and bacteria split once every minute, then at the end of 10 minutes we have  $2^{10}$  bacteria, which equals 1,024. During a linear growth rate, the widgets only increase by a factor of 10; during an exponential growth process, the bacteria increase by over a factor of 1,000.

There is a large difference between 10 units and 1,024 units. In the aforementioned case of linear growth, there is only one generator, or producer, of units. In the second case of exponential growth, each new unit is also a generator. In order to produce exponential growth in the first case, each widget would have to turn into a factory, generating new widgets which then turned into factories, and so on.

As will be explained in a later chapter, this production of a producer does indeed take place in the generative subsystem of an economic system, because machinery such

as machine tools generate the parts, or other substances, that can then be used for their own reproduction. There is therefore a positive feedback process inside the generative subsystem of an economy.

In an ecosystem, as it has long been observed, if any organism was to have all of its progeny survive for a long enough number of generations, the earth would eventually become covered, miles deep, with the descendants of the original pair of organisms. The negative feedback loop in an ecosystem is the necessity of many or all of the units of an ecosystem to expand at approximately the same rate as the exponentially growing units.

For example, in order for a deer population to grow exponentially, their food source would have to grow exponentially, which means that the rain and minerals that the plants need would probably have to grow at an impossible rate, and the ground available to the plants would have to grow exponentially as well. This process of balanced exponential growth can occur for a short time in situations in which, for example, the ecosystem has been wiped out by a volcanic explosion, or a better-adapted group of organisms invade a previously isolated area. But in the normal situation, what is called the *carrying capacity* of an ecosystem limits the growth rate of various of the elements.

The observation of unbalanced growth processes was one of the motivations for the development of the neoclassical economic notion of diminishing returns, which was examined in chapters 2 and 3 of this study. Ricardo explained the progressive deterioration of production on a particular piece of land as the diminishing return to additions to the labor force. From the systemic viewpoint of the framework proposed in this study, however, we can look at the same phenomenon and describe diminishing returns as the operation of negative feedback in a generative system.

Instead of focusing on diminishing returns, the neoclassical model can be recast by describing the land and labor of Ricardo's example as two different functional sectors within an economic system. That is, there are two functions called labor and land in an economy. For production to be maximized, both functional sectors must grow in some logical relation to each other; increases in labor must be accompanied by increases in land in order for the balanced growth of production to take place. For an economy as a whole to grow, all sectors of the economy must grow together in a balanced way.

In the realm of biology, the processes of the ecosystem may lead, in the long-run, to the occurrence of *coevolution*, in which the success of one species is contingent on the success of another; this is the generative negative feedback process in evolution.

There are also allocative feedback processes in an ecosystem. The competition among species is an allocative feedback process. In this situation, the competition must be seen as occurring within a particular niche, or in a particular functional area of an ecosystem, in which the different species are attempting to allocate or share the same resources.

For example, several carnivores may compete to kill a particular kind of herbivore, a task for which the various species of carnivore are well-designed. In such a situation, there may develop a "balance of power" among several species, which would constitute an allocative negative feedback process, or one species may get the upper hand and dominate its competitors, an allocative positive feedback process.

Natural selection is both the struggle among species *within* a niche, and the coevolution of species *across* niches. The struggle among species involves both negative and positive feedback in an allocative way, while coevolution involves a generative

negative feedback process, because the species must evolve together. Both arenas for natural selection, however, are driven forward by the explosive reproductive potential of organisms, a generative positive feedback process.

In the same way, firms in one industrial sector struggle for domination in an allocative process, but firms across industrial sectors cooperate with one another other in a generative process. In both situations, because of the nature of industrial technology, growth can be sustained and nonlinear.

Because the international political system is allocative, only a struggle among units takes place, not a cooperation among units across sectors. Historically, this struggle occurred among states in Europe with different political (and economic) systems. When some better-adapted political economic forms had developed within Europe, the Europeans were able to invade and dominate states with different systems of political economy. Waltz refers to this process as a systems process of competition. In addition, some states more or less voluntarily followed the European example (such as Japan), a process Waltz refers to as socialization.

Where do these processes fit into the general model of a system? Are they part of the unit level or the system level? The structure determines the *type* of the system, whether allocative or generative. If the structure does not include a functional differentiation, then the system will be allocative. If the structure includes a functional differentiation, then the system will be generative.

However, feedback processes are not *part* of the structure, yet they occur at the systems level. They may be thought of as emergent properties, characteristics of the system that are not identifiable from looking at the units in isolation. The feedback

processes involve interactions of the elements, which then effect the structure, which then provides the conditions under which the elements can in turn effect the structure. As Carlsnaes has pointed out, we can still separate the structure and the elements (or agents, as he puts it) if we conceive of systemic processes as the alternation of the effects of unit-level and system-level causes (Carlsnaes 1992; see also Archer 1985). Feedback processes involve the interaction of the elements and the structure. Therefore, feedback processes constitute a third level of a system, in addition to the unit level and the systems level.

In order to develop a systems theory, Waltz warns, one must define systems change. My theory includes mechanisms for systems change. It has been proposed that, in an allocative system, positive feedback can account for structural change; as some units become stronger and stronger, the distribution of capabilities changes, and thus the structure changes. Another way for the distribution of capabilities to change, it has been proposed, is for the capabilities of the generative subsystems of the units of a system to change at different rates, as in the example of the rise and fall of Great Powers.

In a generative system, a change in the functional differentiation of the elements will be a change in the structure. Perhaps the most important change in functional differentiation occurs when the first stage of a sequence becomes reproductive. That is, when the first stage of a sequence is able to reproduce itself, the entire generative subsystem then becomes capable of exponential growth; if there is not a reproductive stage in a sequence, growth can only be linear.

The functions of a generative subsystem may change for reasons internal to the subsystem. Since each element in the subsystem is also a system, the change in nature of

an element at one level is caused by the change in the structure of a system at the level below. But the function of the element may also change; for instance, the lung of air-breathing animals evolved from the air sac of fishes. The change in the functional position of an element in a structure may therefore involve both change in its internal structure as well as change in the domain of the system which is the element. These changes in social systems are often conscious *innovations*; in biological systems, changes in generative systems are often *mutations*.

The negative feedback processes serve to explain continuity and stability, as Waltz has claimed. The political theory of balance of power can be seen as a negative feedback process. It shows why variation in actions of individual units, states, results in less change than one might expect from simply examining the actions themselves. But positive feedback processes can illuminate another facet of systems, the fact that structures of systems create the conditions to actually *accelerate* change.

When a small subset of elements of a system has a relatively large impact on the system because of its potential to exponentially grow or to absorb its neighbors, then we need a systems approach to understand how this can be. Thus, by using a model of systems as enunciated here, we can understand both stability and change in systems.

## **CONCLUSION: A THEORY OF SYSTEMS**

A theory of systems such as the one presented here should itself be a system.

There are several elements of the theory.

First, each system defines a *domain*. Systems in the abstract are linked to systems above and below in a *hierarchy of domains of inquiry*; a domain of inquiry may be divided into subdomains according to certain criteria.

Second, the systems are linked vertically because they are composed of *elements*, each one of which is itself a system.

Third, there is a *structure* in a system, which in turn is composed of an *ordering principle* and *arrangement of parts*. The arrangement of parts are characterized by a combination of one or more of the following: a *functional differentiation*; a *distribution of capabilities/values*; and a *distribution of causal capability*.

Fourth, a *complete system* may be said to be composed of a *generative* subsystem and an *allocative* subsystem, which either have a functional differentiation or no functional differentiation, respectively.

Finally, there exist *positive feedback* and *negative feedback processes*, which operate differently according to whether or not the system is generative or allocative.

The following diagram shows the general model of systems as explained in this chapter:

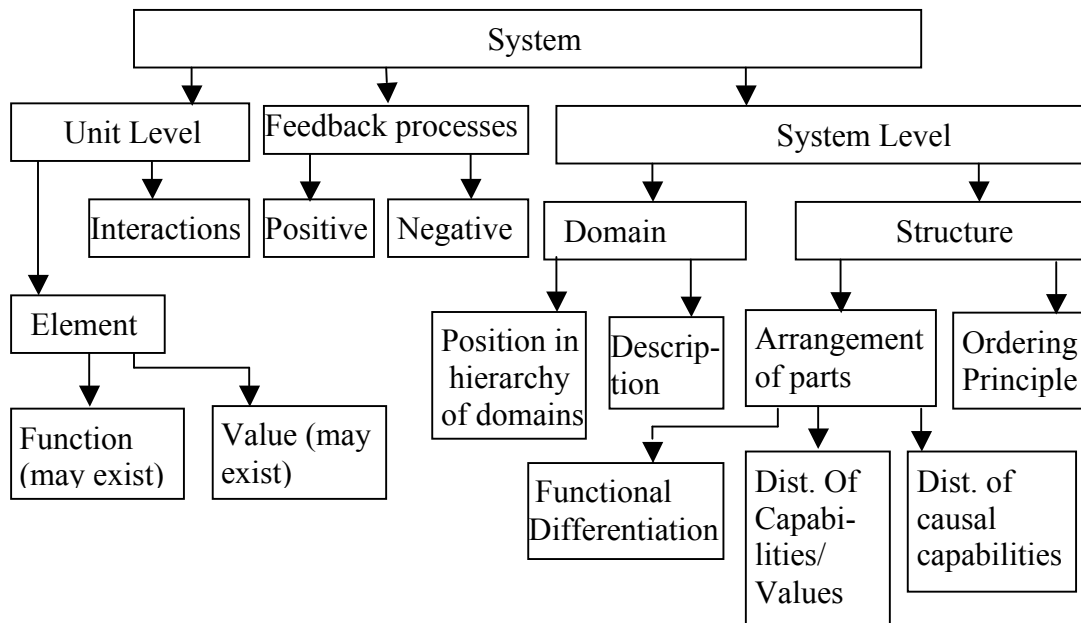

Fig. 16. Complete model of a system.

There can be said to be a structure to this theory, because each element serves a different function. There is no allocative subsystem in this theoretical system, so the theory is a generative system.

This theory of systems helps to generate theories of particular systems. In the next chapters, this theory of systems will be used to generate a theory of economic systems (and within it, a theory of production and capital systems), a theory of political systems, and a theory of systems of political economy.

These theories, in turn, will be used to generate hypotheses. A theory of a particular system is used to generate hypotheses that can be validated or refuted.



Thus, chapters five through 10 of this study have a generative structure, illustrated by the following diagram:

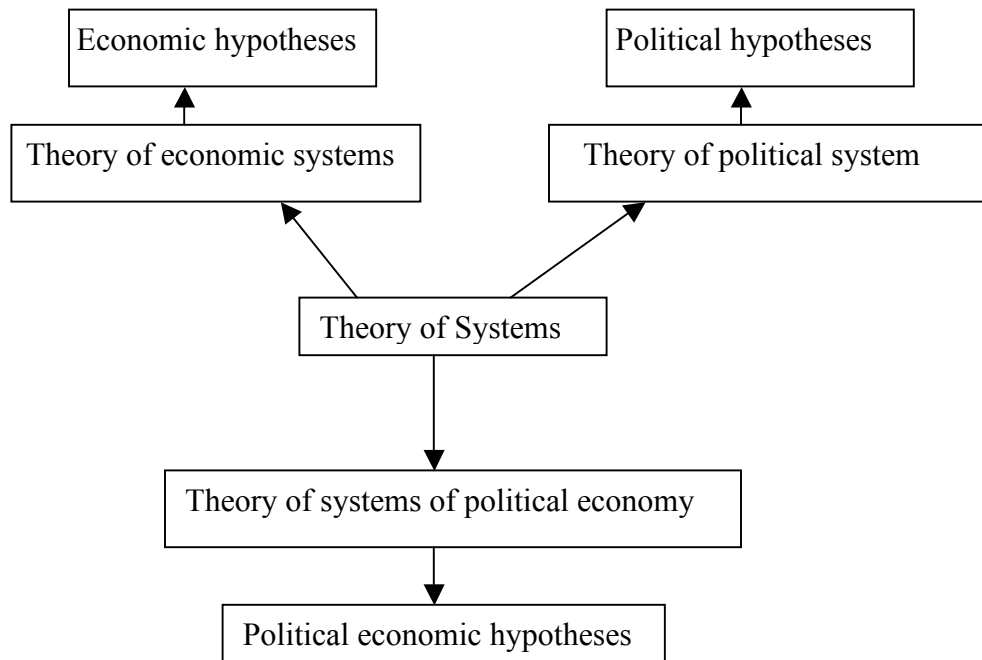

Fig. 17. Structure of chapters.

This study has a two-dimensional sequential structure, in which the theory of systems is most important, the theories of particular systems are second in importance, and the hypotheses have the least capability to influence the theory as a whole. This system of theories and hypotheses can be referred to as a paradigm, or as a theoretical framework.

Thomas Kuhn (Kuhn 1970) developed the concept of a paradigm in order to explain change in scientific theories. He used the concept in many ways (one scholar famously counted over twenty uses [Masterman 1970]), but the core of his concept seems to have been that a paradigm is a network of theories and hypotheses that hang together in a kind of *gestalt*, or totality. The term has since been used, popularly, to characterize

changes in ideas ranging from advertising slogans to investment strategies. I will use the term *theoretical framework* instead, for the purpose of identifying a theoretical system which has a theory of systems, theories of particular systems which are consistent with the theory of systems, and hypotheses which are generated by using the theories of particular systems.

Since there is a theory of systems embedded in the theoretical framework, a logical consistency among the parts of the theory is easier to maintain. The framework generates itself, instead of being constructed in an ad hoc manner.

The diagram of the paradigm shows three stages of a sequence: a theory of systems, or metatheory; theories of particular domains, or theories; and hypotheses. This tripartite sequence is a useful one for explaining generative systems.

The last stage of a tripartite generative sequence involves the production of the output that is being generated by the system as a whole. For example, the GDP (gross domestic product) of a national economy, the enforcement of laws in a state, or the leaves on a tree, can be seen as the output of the generative subsystems in an economy, state, or biological community, respectively. This stage can be called the *production stage*, because the final output is being produced.

The middle stage of the sequence involves the production of the elements which participate in the last, production stage. Thus, the production of production machinery, the creation and regulation of bureaucratic “machinery”, and the organs involved in tree growth are the middle stage of the economic, political, and biological community systems, respectively. This stage can be called the *generator stage*, because the generators of the output are created at this point in the sequence.

The first stage is the part of the sequence in which the objects which create the generators are produced. In addition, if there is a reproductive aspect of the system, this is where reproduction takes place; at the *metagenerator* stage, the metagenerators create the generators and may reproduce themselves. For example, a particular subset of machinery, to be called reproduction machinery in the chapters on economic systems, both creates more reproduction machinery and is used to generate production machinery. In a state, the political elites create the bureaucratic machinery. The political elites may reproduce themselves, as in a dictatorship (literally in a kingship) or they may simply be regenerated, as in a democracy. In a biological community, the reproductive apparatus of trees provides the machinery which will generate more reproductive organs as well as the mechanisms of tree growth.

We can diagram these sequences in the following way:

	Economy	Polity	Community	Paradigm
Metagenerator	Reprod. Machinery	Political Elites	Reproductive Organs	Systems Theory
Generator	Prod. Machinery	Bureaucracy	Growth Mech.	Theory
Production	Final Production	Enforcement	Leaf growth	Hypotheses

Fig. 18. Examples of tripartite sequences.

Thus, there is a consistent model which can be used in the next chapters to characterize the economic, political, and political economic systems. This model is consistent within itself, because the theory can also be conceived of as a system. By specifying these systems, certain conclusions will be reached in chapter 10 concerning

the causes of the rise and decline of Great Powers. Throughout chapters 5 through 10, hypotheses will be proposed based on the discussion of the various systems.

Thus, the constructive parts of this study will follow a tripartite organization as well: first a theory of systems is presented; then, a set of theories of particular systems is articulated; and finally, a set of hypotheses will be generated.

By constructing an abstract framework in this chapter, I will be able to propose theories and hypotheses concerning the definition of a Great Power, and most importantly, technological change in production. These theories and hypotheses will not be ad hoc, as I claim the theories and hypotheses of the scholars reviewed in chapter 1 through 3 were prone to be. The theoretical framework as proposed in this chapter will be useful for understanding the processes of the rise and decline of Great Powers in the following chapters.